



**Western Kentucky University
Technical Assistance Center for Water Quality
Center for Water Resource Studies**

**“Supporting Small Water Systems in
Meeting the Goal of Public Health Protection”**

<http://water.wku.edu>
(270) 745-8895

Grant Number X83123601

**Quarterly Report
for the period
October 1 – December 31, 2006**

Submitted to:
**U.S. Environmental Protection Agency
Office of Water
January 31, 2007**

Introduction

The Technical Assistance Center for Water Quality at Western Kentucky University (TACWQ WKU) serves to support capacity development of small drinking water systems through the Utility Management Institute, a circuit rider, source water investigations, and information technology. The goal of the Center is to help small systems meet the requirements of the Safe Drinking Water Act (SDWA) and ensure public health. While focused on solving local problems that can serve as national models, the TACWQ is impacting small systems throughout the country.

The Center accomplishes its goals by relying on its diversified staff, in-house laboratory capabilities (WATERS), and subcontractors such as Kentucky Rural Water Association (KRWA) and Spatial Data Integrations (SDI). Below are the activities that were conducted toward these goals for the first quarter of the grant year, October 1-December 31, 2006.

Kentucky Rural Water Association

The Kentucky Rural Water Association (KRWA) provides training, technical assistance, advocacy, and a variety of other services and benefits to water districts, sanitation districts, water associations, and municipalities under 10,000 in population. KRWA's basic training and technical assistance services are provided to all utilities that request help, regardless of membership status.

Utility Management Institute

This project supports EPA Strategic Plan Goal 2 of Clean and Safe Water, Objective 2.1: Protect Human Health and Sub-Objective 2.1.1: Water Safe to Drink by increasing the overall proficiency of community water system managers for providing safe water.

The Utility Management Institute (UMI) was created, in a collaborative effort between WKU and KRWA, to provide utility managers, and other utility personnel, with the opportunity to gain valuable knowledge and earn a university-based, professional designation in the field of management. These goals can be accomplished through the successful completion of six modern, practical management courses, specifically developed for public water utility personnel. The Utility Management Institute rewards its participants with the Utility Management Professional (UMP) designation after completion of all six courses.

During the quarter, the course entitled "Utility Management 101" was presented in Slade, Kentucky on November 14-16, 2006 at Natural Bridge State Resort Park. There were thirty-three (33) students participating in this course. The Utility Management Institute now claims a total of two hundred seventy-six (276) students. One hundred nineteen (119) of our students have now completed all six of the courses in the UMI Series and have been awarded the Utility Management Professional designation.

An Alumni Appreciation event and Train-the-Trainer conference was conducted on October 11-12, 2006 in Bowling Green, Kentucky. This event honored the UMP designees and allowed us

to share the UMI concept with technical assistance providers from other states. Approximately 40 of the UMP designees attended the first day. Eleven representatives from nine different states attended the train-the-trainer session.

UMI brochures were mailed during the quarter to promote the program and advertise the UMI class schedule for 2007.

Small System Circuit Rider

This project supports EPA Strategic Plan Goal 2 of Clean and Safe Water, Objective 2.1: Protect Human Health and Sub-Objective 2.1.1: Water Safe to Drink by providing on-site technical assistance to community water system operators.

The Small System Circuit Rider continues to provide quality technical assistance and training to management and personnel from small public water systems throughout Kentucky. This segment of public water systems, serving under 3,300 in population (especially those serving under 500 in population), is difficult to help through traditional means. These very small systems are often not eligible for assistance through our other Circuit Rider programs (USDA funded) because they are privately owned or are not credit worthy. Hands-on assistance delivered on-site, with active follow-up assistance, is the best way to help these systems comply with the ever-increasing complexities of the Safe Drinking Water Act (SDWA).

During the first quarter, the Circuit Rider position logged 551.5 hours. Of that time 28% of the total time was spent directly assisting systems or their personnel including 155.75 hours on-site working with systems, 12.5 hours developing plans and reports for systems, and 78.0 hours providing formal training and program outreach.

The majority of time this quarter was spent assisting systems with infrastructure mapping. Activities for technical assistance included GPS-GIS mapping, source water protection and water quality monitoring. Compliance assistance included water system evaluation, monitoring plans and CCR preparation. Management/financial assistance included water accountability and cost of service analysis.

Significant Contacts:

City of Campton – Located in Wolfe County Kentucky serving 1,867 water and 240 sewer customers.

Campton is a rural farming and logging community in eastern Kentucky. The city provides drinking water throughout the county from a small reservoir. The watershed is 675 acres and the reservoir covers 15.6 acres. Over the past two years the reservoir has been in drought condition and the city has had to purchase water from two other systems. To complicate the situation the growth has pushed the water plant production to 500,000 gpd despite a permitted withdrawal of 330,000 gpd. This has put their permit in jeopardy with the KY Division of Water.

The water plant superintendent contacted KRWA and the Kentucky Geological Survey for assistance in developing a supplemental groundwater supply. The Circuit Rider has installed water level monitoring stations at two wells and the reservoir along with a rain gauge to capture background water level data. The next step is to profile water quality in the wells prior to the KGS conducting an aquifer pumping test. The Circuit Rider will then monitor water quality during the test and collect “time interval samples.” The testing should be concluded by the end of February.

Warren County Water District

In an effort to expand and improve the services rendered by the CWRS, KRWA jointly with the CWRS and SDI, responded to an RFP from the water district. The RFP was awarded to our group to provide professional GPS mapping services as a pilot study. The pilot area covered all water and sewer infrastructure within a 10 square mile region of their system. These features included meters, valves, hydrants, pump stations and manholes. This brought together both the water and wastewater circuit rider programs plus industry and university collaboration. A total of 1,723 features were mapped and inspected. The project was a means to evaluate the CWRS’s ability to manage and complete a large mapping project so that in the future students could gain real world experience. The pilot study was a success. The project was completed on time and the accuracy of the data surpassed the expectations of the water district.

Spatial Data Integrations

Spatial Data Integrations, Inc. (SDI) is a full service geospatial firm offering a wide variety of mapping services and geographic applications, including imagery processing, natural resource data collection, photo interpretation, geospatial file management and Geographic Information Systems (GIS). SDI provides customized GIS applications and services to rural utilities and small municipalities. SDI has close ties to the rural water community and strives to be an industry innovator.

Asset Management

This project supports EPA Strategic Plan Goal 2 of Clean and Safe Water, Objective 2.1: Protect Human Health and Sub-Objective 2.1.1: Water Safe to Drink by developing an asset management tool for water systems to more efficiently inventory and track their infrastructure and physical assets.

Many small water utilities in the United States have had infrastructure in the ground for over 50 years, much of which is now coming towards the end of its life cycle. Increasingly, utilities are looking for monies or best practices that will enable them to rehabilitate their aging infrastructure and to continue to offer one of America’s most critical public health, economic and environmental assets. Asset management is one practice that small utilities can use to maintain their infrastructure and plan for upcoming rehabilitation or replacement in a more efficient and cost-effective manner.

Spatial Data Integrations (SDI) intends to develop a pilot web-based asset management system for small systems based upon the existing EPA guidance document “Asset Management: A Handbook for Small Water Systems” (EPA-816-R-03-16). This tool will show the utility personnel and community leaders the ‘big picture’ of their aging infrastructure and allow them to effectively plan capital improvements and/or needed repairs.

Due to unforeseen issues at EPA, SDI did not receive its subcontract for this year’s grant until late December 2006. Therefore, progress on the web-based asset management application has been delayed. SDI is currently seeking a qualified WKU intern to assist on the project.

Technical Assistance

This project supports EPA Strategic Plan Goal 2 of Clean and Safe Water, Objective 2.1: Protect Human Health and Sub-Objective 2.1.1: Water Safe to Drink by providing TACWQ personnel with GIS expertise and capabilities, which will further the TACWQ’s mission of providing small water systems with infrastructure mapping assistance.

SDI continues to provide approximately 300 square feet of office space and high-speed Internet access to TACWQ staff members and student workers. Assistance provided this quarter included: training on how to collect Global Positioning System (GPS) data using the new sub-foot H-Star technology, support with providing technical assistance to Webster County Water District regarding their GIS data, and general consulting on various GIS tasks performed by student workers.

WATERS Laboratory

Water Analysis, Training, Education and Research Services (WATERS) is a water quality laboratory located on WKU’s campus. WATERS espouses the following integrated goals through cooperation:

- a) **Water Analysis:** Certified drinking water laboratory for chemical and biological analyses.
- b) **Training:** Providing training of field, laboratory and environmental technicians serving an immediate need for the Commonwealth of Kentucky.
- c) **Education:** Student certification program, hands-on work experience for undergraduate students in the environmental science field.
- d) **Research:** Developing more accurate and cost-effective methods of analysis for microbial source tracking.
- e) **Service:** Enabling local, state and regional private and public sector entities to meet environmental management goals through the provision of high quality environmental data collection, management and analysis.

Small Systems Partnership for Compliance Monitoring

This project supports EPA Strategic Plan Goal 2 of Clean and Safe Water, Objective 2.1: Protect Human Health and Sub-Objective 2.1.1: Water Safe to Drink by reducing the financial burden on small water systems of routine water quality analyses required under the SDWA.

WATERS continues to partner with small water systems in Kentucky for the purpose of establishing effective and economical methods for meeting compliance monitoring requirements. During the quarter, microbiological analyses were conducted for 8 drinking water systems with populations less than 10,000. Five of these systems have populations less than 3,300. A total of 121 analyses were conducted for these eight systems during the quarter. Bacteriological Analysis Report Forms were sent to the KY Division of Water electronically in compliance with state reporting requirements.

Microbial Source Tracking Analytical Method Development

This project supports EPA Strategic Plan Goal 2 of Clean and Safe Water, Objective 2.1: Protect Human Health and Sub-Objective 2.1.1: Water Safe to Drink by establishing cost-effective methods of tracking source water contamination.

The ability to track bacterial contaminants in water to their source is a major focus of source water protection. Many research projects have been performed on the subject. However, the only conclusion that most research has reached is that each region of the research area possesses different microorganisms in its waters. This proposal is to study source tracking techniques in the Lower and Upper Green River Watershed region of the Commonwealth of Kentucky. The ultimate environmental outcome of the project is cleaner source water by identification and reduction or elimination of the sources of fecal contamination in source waters. An extension of this work could lead to a reduction in the amount of treatment needed to make surface waters potable, thereby reducing costs.

During the quarter, the most recently published articles on bacterial source tracking were researched. PCR primers and protocols to be used on the project were determined. Samples were filtered and preserved for later analysis.

LT2 Rule: Cryptosporidium Assistance

This project supports EPA Strategic Plan Goal 2 of Clean and Safe Water, Objective 2.1: Protect Human Health and Sub-Objective 2.1.1: Water Safe to Drink by assisting water systems with implementation of the Long Term 2 Enhanced Surface Water Treatment (LT2) Rule.

WATERS Laboratory was notified by EPA's Office of Ground Water and Drinking Water (OGWDW) in Cincinnati, Ohio on October 18, 2006 that it had been granted "Approved" status for the analysis of Cryptosporidium under the LT2 Rule.

On October 11, 2006, a presentation was given in conjunction with a KRWA training event in Carrollton, Kentucky which covered the basics of the LT2 Rule and how to sample for

Cryptosporidium. There were 36 participants in the class, and continuing education units (CEUs) were offered.

WATERS worked with Water Services Corp of Middlesboro, KY to develop a LT2 monitoring plan for submission to the EPA. The plan includes all identification information, the sampling location description, as well as the monitoring schedule for the PWS. WATERS also discussed LT2 requirements with Ohio County Water District and Logan Aluminum during the quarter. Method 1623 was demonstrated for representatives of Wood Creek Water District.

An undergraduate student, Jennifer Dean, was hired and trained on the filtration method for Cryptosporidium samples.

A prototype source water filtration unit has been developed, which allows water systems to filter their Cryptosporidium samples on-site and ship the filter to their laboratory, rather than ship the entire 10 liters of water. The unit was field-tested at the City of Scottsville water treatment plant and demonstrated to representatives of Water Services Corp. This unit is a manual filtration unit, and plans are underway to develop an automated unit in the coming months.

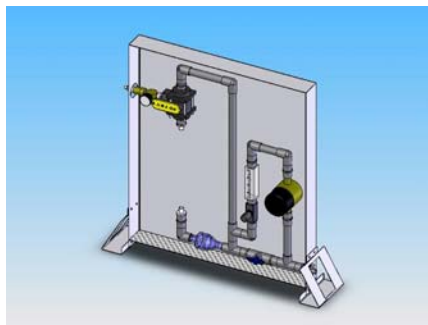

Figure 1. Case and device assembly for manual filtration unit.

Center for Water Resource Studies

Environmental Informatics

This project supports EPA Strategic Plan Goal 2 of Clean and Safe Water, Objective 2.1: Protect Human Health and Sub-Objective 2.1.1: Water Safe to Drink by increasing the amount of information technology available to water systems, and presenting it in a format that is easy to understand.

Specific activities under this objective include:

Decision Support System

The Decision Support System (DSS) is a planning resource that serves to establish partnerships and assist stakeholder groups in minimizing the effects of agricultural, industrial, and municipal impacts on source water. The DSS will incorporate a rules based system to allow for a customizable schedule.

The Rules Based System developed by the Center utilizing Java has been converted to work with ArcGIS desktop. When completed, this will allow the users to evaluate data for data entry errors. The system is currently being modified to include rules that are user defined. Documentation and instructions on use of the system are being developed, and will be made available through the water.wku.edu web site.

As part of the tools available through the DSS website, the Water Loss Calculator was modified to take into account additional totals that were requested by water systems. The new version will be available on the web site next quarter, and is currently in the process of being documented. This tool allows water districts to enter the amount of purchased and produced water and amounts of water accounted for during loss, such as flushing. The tool will then calculate water loss that is unaccounted for, to help predict water loss due to an unknown system break.

System Mapping Assistance

Many rural water systems lack the technology and skill required to digitally map their infrastructure. Rural systems without GIS data collecting capabilities will be assisted, through mapping efforts of the Center. Field crews will be deployed to collect GIS information that will be incorporated into the DSS and Asset Management tools. This data will also be provided to the systems in a digital format. A minimum of two rural water systems will be provided mapping assistance during the grant year. The systems in need of assistance will be identified through Kentucky Rural Water Association.

During the quarter, CWRS worked with KRWA and identified Adairville Water Works located in Logan County, KY (population: 1,307) as the first small water system that will be provided with mapping assistance.

Relational Database Tool

Large volumes of laboratory data from different sources have made data exchange between different applications very difficult. In this project, we plan to expand on software previously developed to facilitate data exchange.

An XML format tool to convert OCR documents has been developed and is now available through the TACWQ. Documentation and instructions on use of the system have been developed and are under review. This information will be made available through the water.wku.edu web site during the next quarter.

Web Page Hosting

Many small water systems do not have the financial or technical resources to develop and host their own websites, yet currently websites are one of the best tools to quickly disseminate information to the public. Using the website as a media to transmit information to clients within the rural water district, systems can quickly provide information about water quality (CCR reports), boil water advisories, meeting times and locations, and additional crucial information.

Currently, seven small water system websites are being hosted at no cost to the systems. During the quarter, discussions took place with Webster County Water District regarding the potential for CWRS to host a mutual aid agreement website for Kentucky Water Districts.

Technology Training

As the use of technology develops, the need for technology training increases. A presentation for water districts will be provided at a local or state conference to help demystify the technology tools available to them. Areas to be included will be web site development, applicable software tools and basics of their use, and basic PC support. Topics covered will include tools previously developed by the TACWQ and other states. CDs of the available tools will be distributed to attendees of the presentation. Also covered will be basic computer terms, backup information, open source software that is available, viruses, firewalls, and other computer security issues.

In addition to the conference presentation, a technology training manual is currently under development. It will include documentation on tools developed by the TACs, commercial software, and open source software that is available to water systems. Basic instructions on using technology for marketing, customer awareness, and system evaluation will also be included. This manual will be available in hard copy form or on a CD, and can be used by small water systems throughout the country.

Center Coordination

This project supports EPA Strategic Plan Goal 2 of Clean and Safe Water, Objective 2.1: Protect Human Health and Sub-Objective 2.1.1: Water Safe to Drink by providing outreach to small water systems, and maximum efficiency between all project team components and concurrent activities.

Specific activities under this objective include:

Quarterly Reports

The TACWQ will continue to provide quarterly technical and financial status reports to the EPA project officer. This is the first quarterly report for the current grant year, which covers the period October 1, 2006 to December 31, 2006.

Education and Outreach

The TACWQ will display a tabletop exhibit at relevant national, regional and state conferences and meetings, either in conjunction with another TAC or with the entire TACNET. TACWQ personnel will make themselves available to attend meetings on emerging issues.

The tabletop display is currently in the process of being revised to more accurately reflect the current activities of the Center. The new display will be exhibited next quarter at the Applied Research and Technology (ARTP) Expo and the Kentucky Water and Wastewater Operators

Association (KWWOA) 50th annual conference. Plans are also underway to participate in the joint TACNet exhibit at the annual American Water Works Association (AWWA) annual conference in June.

Stakeholder Advisory Council

A minimum of one Stakeholder Advisory Council (SAC) meeting will be held during the grant year in order to ensure that activities, proposed and ongoing, of the TACWQ accurately reflect the needs of its constituents. The SAC provides advice to the TACWQ Director on strategic issues related to the science and technology missions of the TACWQ including insights on research directions and policy, and perspectives from the broader community and political scene.

Plans are currently underway to host the annual SAC meeting in conjunction with Ogden College's ARTP Expo in Bowling Green on March 1, 2007.

Budget

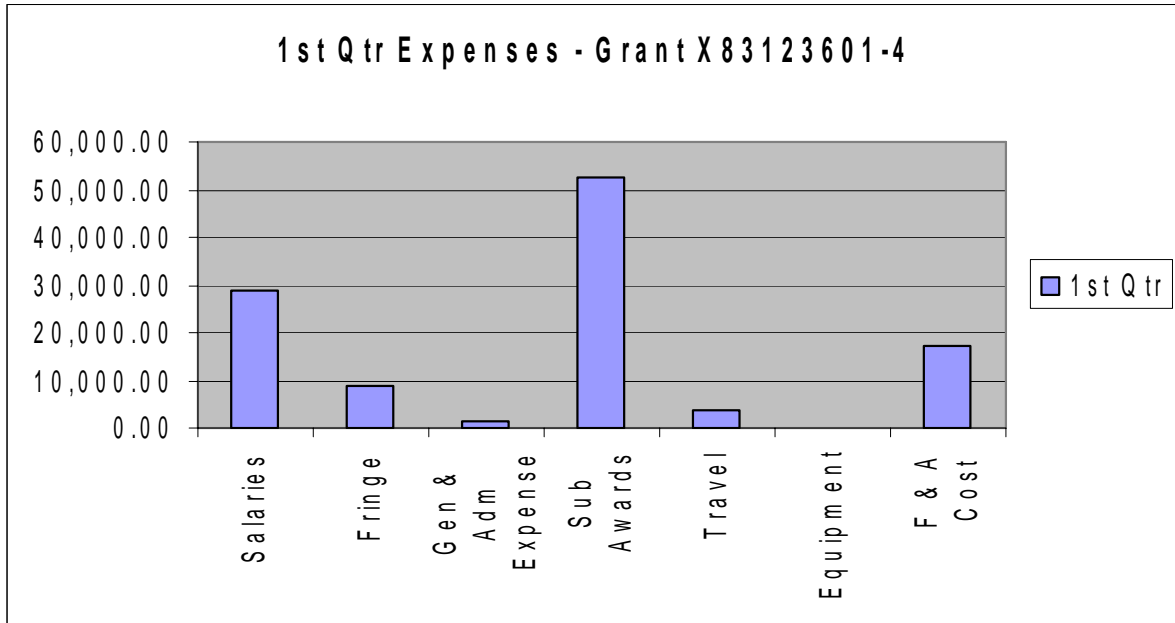

1st Quarter Expenditures	Oct - Dec, 2006
Salaries	28,609.81
Fringe	8,689.04
Gen & Adm Expense	1,551.83
Sub Awards	52,361.44
Travel	3,916.99
Equipment	0.00
F & A Cost	17,156.65
Total Expenditures	112,285.76